

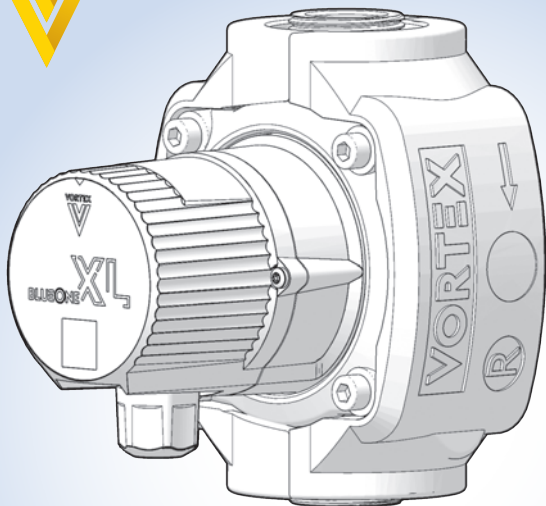

DE
—
EN
—
FR
—
IT



BWO 200 QUICK-GUIDE



www.deutsche-vortex.com/200

▼ SICHERHEIT

DE

Installation, elektrischer Anschluss und Inbetriebnahme der Pumpe müssen von Fachpersonal und unter Einhaltung der allgemeinen und örtlichen Sicherheitsvorschriften erfolgen.

Vor allen Montage- und Wartungsarbeiten Motor spannungsfrei schalten und gegen Wiedereinschalten sichern.

Dieses Gerät kann von Kindern ab 8 Jahren sowie von Personen mit eingeschränkten physischen, sensorischen oder mentalen Fähigkeiten sowie von Personen mit mangelnder Erfahrung bzw. fehlendem Wissen nur dann verwendet, gereinigt oder gewartet werden, wenn sie beaufsichtigt oder bezüglich des sicheren Gebrauchs des Gerätes unterwiesen wurden und die daraus resultierenden Gefahren verstehen. Kinder dürfen nicht mit dem Gerät spielen.

▼ SAFETY

EN

Installation, electrical connection and setting up of the pump must be carried out by skilled personnel in compliance with the general and local safety regulations in force.

Before carrying out any installation or maintenance work, disconnect motor from power supply and ensure it cannot be reconnected unintentionally.

This device may only be used, cleaned or maintained by children aged 8 years and over, persons with limited physical, sensory or mental faculties, as well as persons with limited experience or lack of knowledge, under supervision or after they have been instructed for the safe use of the device and understand the resulting dangers. Children are not allowed to play with the device.

▼ SÉCURITÉ

FR

L'installation, le branchement électrique et la mise en service de la pompe doivent être effectués par du personnel spécialisé dans le respect des normes de sécurité générales et locales en vigueur.

Avant tout travail de montage et de maintenance, mettre le moteur hors tension et le sécuriser contre une remise en marche.

Cet appareil ne peut être utilisé, nettoyé et réparé par des enfants âgés de 8 ans ou plus, ainsi que par des personnes souffrant d'un handicap physique ou mental ou bien d'une déficience sensorielle, et par des personnes souffrant d'un manque d'expérience ou de connaissances, sauf si elles ont bénéficié d'une surveillance ou d'instructions préalables concernant la sécurité d'utilisation de l'appareil, et si elles ont compris les risques qui en résultent. Les enfants ne doivent pas jouer avec l'appareil.

▼ SICUREZZA

IT

L'installazione, l'allacciamento elettrico e la messa in esercizio della pompa devono essere eseguite da personale specializzato nel rispetto delle norme di sicurezza generali e locali vigenti.

Prima di eseguire interventi di montaggio e manutenzione si deve disinserire la tensione di alimentazione del motore e fare in modo che non possa essere reinserita inavvertitamente.

L'utilizzo, la pulizia e la manutenzione di questo dispositivo sono consentiti ai bambini dagli 8 anni in su, nonché a persone con capacità fisiche, sensoriali o mentali limitate o a persone senza esperienza o con mancanza di conoscenze solo se le suddette persone sono sorvegliate o se sono state istruite sull'utilizzo sicuro del dispositivo e sono in grado di comprendere i rischi che ne derivano. I bambini non devono giocare con il dispositivo.



max. 95 °C



max. 10 bar



max. 40 °C

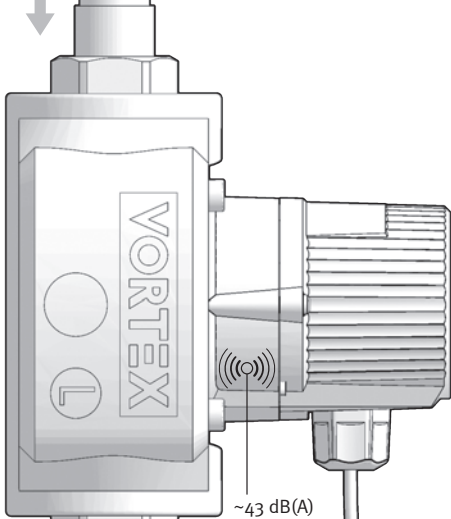

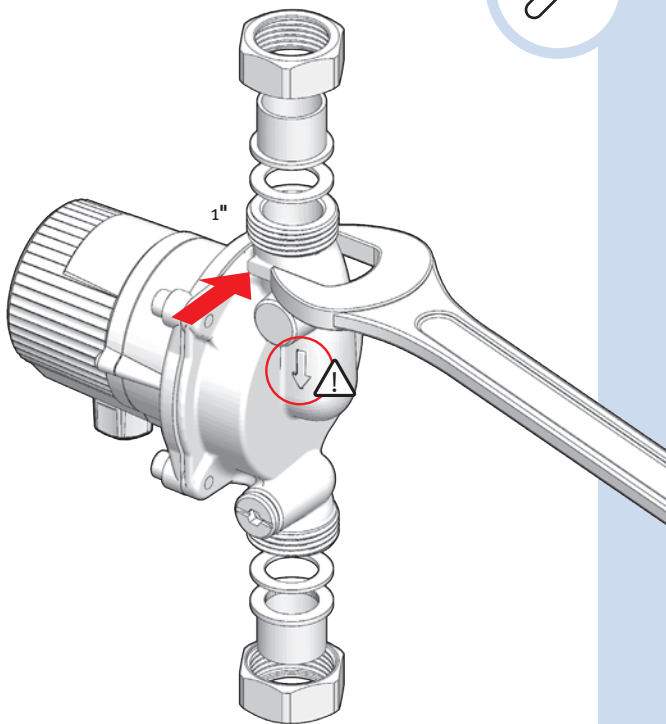



1

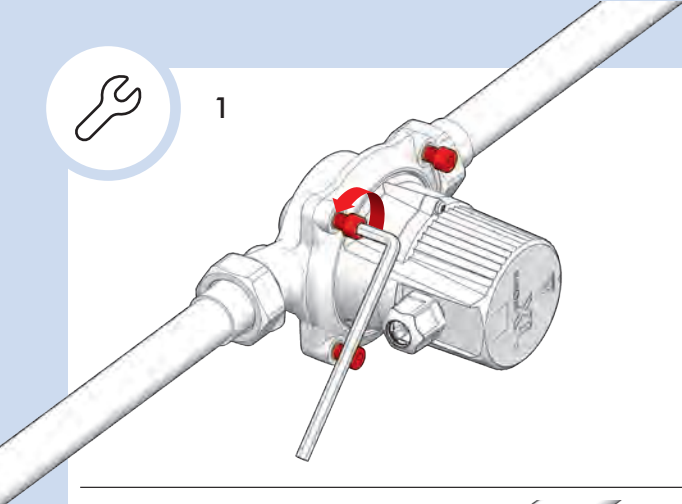

2

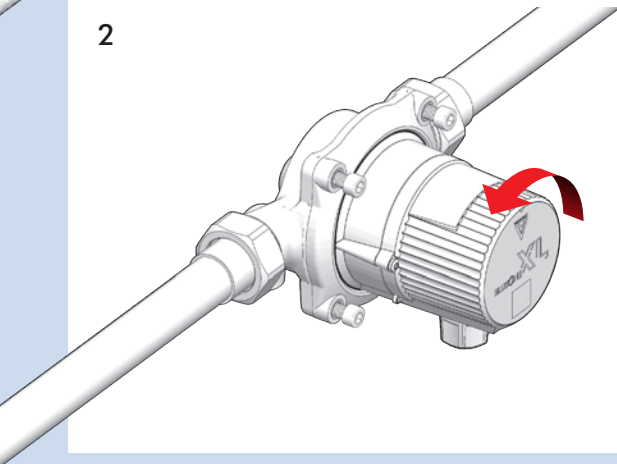

3

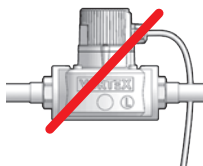
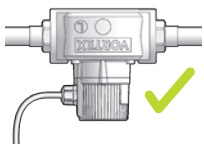
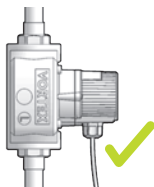
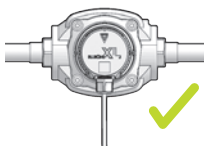
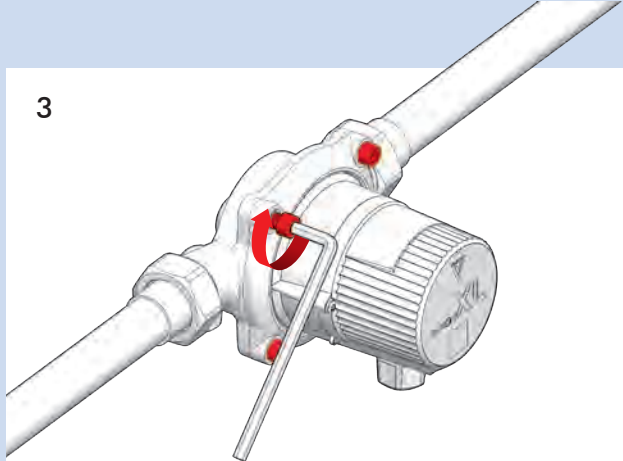



1

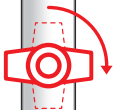
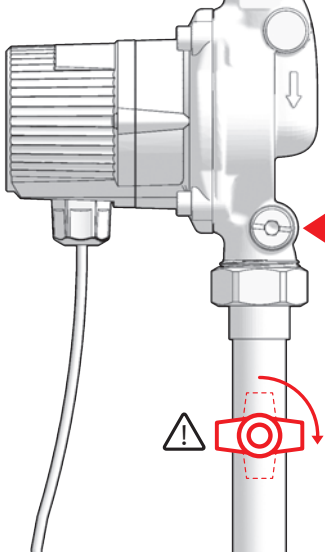
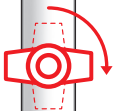

2

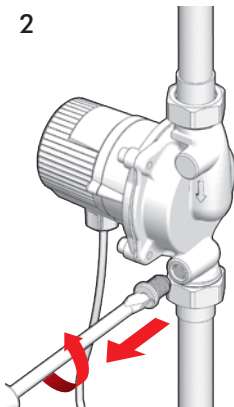

3

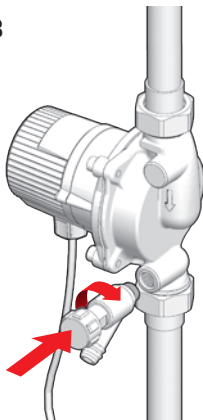

4

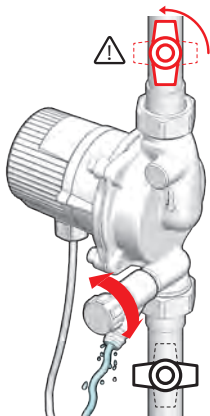

6

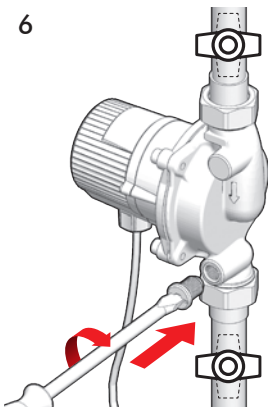

5

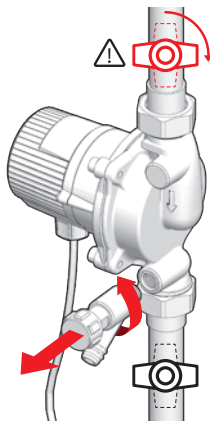

7

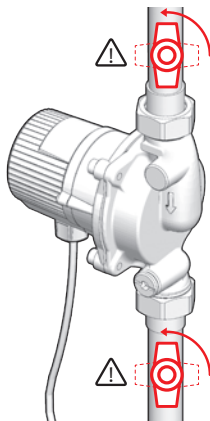

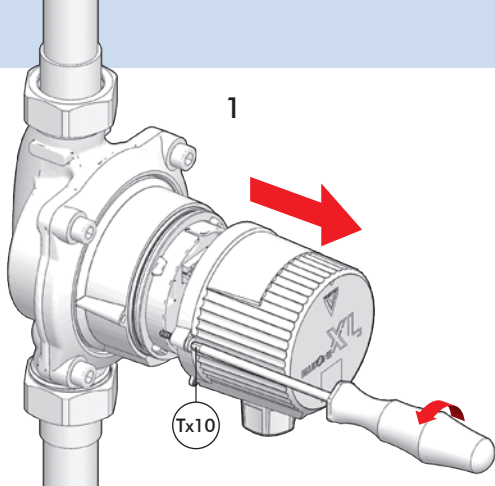

2

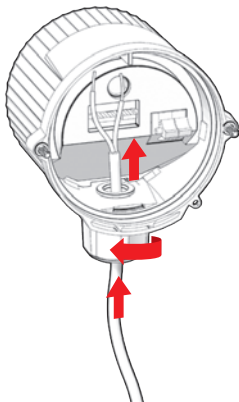

3

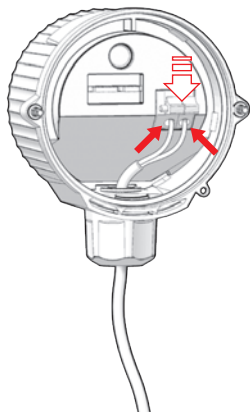

4

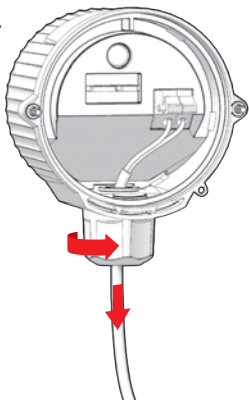

5

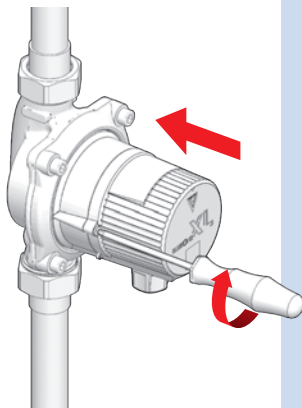

6

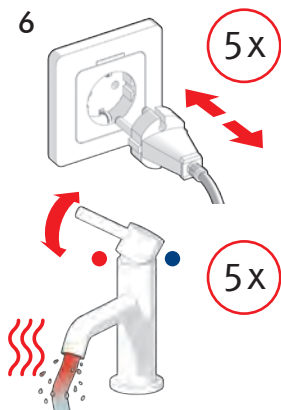

7

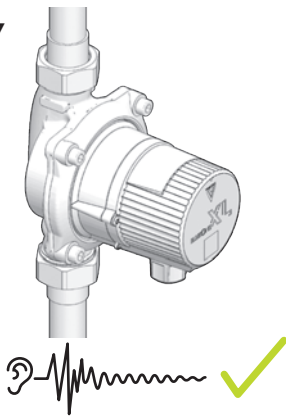

▼ EU-KONFORMITÄTSERKLÄRUNG

DE

Dieses Produkt entspricht den geltenden europäischen Richtlinien sowie den ergänzenden nationalen Anforderungen und Normen. Die Konformität wurde nachgewiesen.

Die EU-Konformitätserklärung des Produktes kann unter **www.deutsche-vortex.de** abgerufen oder direkt bei der Deutsche Vortex GmbH & Co. KG angefordert werden.

▼ EU-DECLARATION OF CONFORMITY

EN

This product meets the applicable European directives and the complementary national requirements and standards. Conformity has been proven.

The declaration of conformity can be retrieved under **www.deutsche-vortex.com** or directly from Deutsche Vortex GmbH & Co. KG.

▼ DÉCLARATION UE DE CONFORMITÉ

FR

Ce produit correspond aux directives européennes en vigueur ainsi qu'aux exigences et normes nationales complémentaires. La conformité a été démontrée.

La déclaration UE de conformité du produit peut être consultée sur le site **www.deutsche-vortex.com** ou demandée directement auprès de la Deutsche Vortex GmbH & Co. KG.

▼ DICHIARAZIONE DI CONFORMITÀ UE

IT

Questo prodotto è conforme alle direttive europee in vigore, nonché alle norme e ai requisiti nazionali integrativi. La conformità è stata comprovata.

La dichiarazione di conformità UE del prodotto può essere visualizzata sul sito **www.deutsche-vortex.com** oppure può essere richiesta direttamente presso la Deutsche Vortex GmbH & Co. KG.



▼ **ENTSORGUNG**

DE

Das Symbol auf dem Produkt oder der Verpackung bedeutet, dass das Produkt einer getrennten Erfassung für elektrische und elektronische Geräte zugeführt werden muss und nicht über den normalen Haushaltsabfall entsorgt werden darf. Durch die korrekte Entsorgung tragen Sie dazu bei, negative Auswirkungen auf die Umwelt und die menschliche Gesundheit zu vermeiden, die durch unsachgemäße Erfassung und Behandlung von Elektroaltgeräten entstehen können.

Für weitere Informationen kontaktieren Sie bitte Ihre Kommunalverwaltung, den Abfallentsorger oder das Geschäft, in dem Sie das Produkt erworben haben.

▼ **DISPOSAL**

EN

The symbol of the crossed out wheeled bin on the product or on the packaging means that this product has to be disposed of separately from household waste at a collection point for the recycling of electrical and electronic equipment. By ensuring this product is disposed of properly, you will help prevent potential negative effects for the environment and human health, which could be caused by inappropriate waste handling of EEE.

For more detailed information about the recycling of this product, please contact your local Civic Office, your household waste disposal service or the shop where you purchased the product.

▼ **RECYCLAGE**

FR

Sur le produit ou son emballage, le symbole de la poubelle barrée signifie que ce produit doit être jeté séparément des ordures ménagères, en un point de collecte pour le recyclage des équipements électriques et électroniques. En assurant un correct recyclage du produit, vous aiderez à la prévention d'effets potentiellement négatifs sur l'environnement et la santé humaine qui pourraient être causés par une manutention inappropriée de déchets de tels équipements.

Pour une information plus détaillée sur le recyclage de ce produit, veuillez contacter votre mairie, votre service de recyclage des déchets ménagers ou le lieu où vous avez acheté le produit.

▼ **SMALTIMENTO**

IT

Questo simbolo sul prodotto o sulla confezione indica che il prodotto non deve essere considerato come un normale rifiuto domestico, ma deve invece essere consegnato ad un punto di raccolta appropriato per il riciclo di apparecchi elettrici ed elettronici. Assicurandovi che questo prodotto sia smaltito correttamente, voi contribuirete a prevenire potenziali conseguenze negative per l'ambiente e per la salute che potrebbero altrimenti essere causate dal suo smaltimento inadeguato.

Per informazioni più dettagliate circa il riciclaggio di questo prodotto, potete contattare l'ufficio comunale, il servizio locale di smaltimento rifiuti oppure il negozio dove l'avete acquistato.



www.deutsche-vortex.com/200

design: raumkontakt.de 199-130-392 • 03/22



DEUTSCHE VORTEX GMBH & CO. KG

Kästnerstraße 6 | 71642 Ludwigsburg | Germany
Phone: +49(0)7141.2552-0 | Fax: +49(0)7141.2552-70
info@deutsche-vortex.com

WWW.DEUTSCHE-VORTEX.COM